

SECTION **CHG**  
CHARGING SYSTEM

A  
B  
C  
D  
E  
F  
G  
H  
I  
J  
K  
L  
N  
O  
P

CONTENTS

<b>BASIC INSPECTION</b> .....	3	<b>CHARGING SYSTEM</b> .....	19
<b>DIAGNOSIS AND REPAIR WORKFLOW</b> .....	3	Symptom Table .....	19
Work Flow .....	3	<b>PRECAUTION</b> .....	20
<b>SYSTEM DESCRIPTION</b> .....	6	<b>PRECAUTIONS</b> .....	20
<b>CHARGING SYSTEM</b> .....	6	Precaution for Supplemental Restraint System (SRS) "AIR BAG" and "SEAT BELT PRE-TENSIONER" .....	20
System Diagram .....	6	Precaution for Power Generation Voltage Variable Control System .....	20
System Description .....	6	<b>PREPARATION</b> .....	21
Component Parts Location .....	6	<b>PREPARATION</b> .....	21
Component Description .....	7	Special Service Tools .....	21
<b>POWER GENERATION VOLTAGE VARIABLE CONTROL SYSTEM</b> .....	8	Commercial Service Tools .....	21
System Diagram .....	8	<b>PERIODIC MAINTENANCE</b> .....	22
System Description .....	8	<b>CHARGING SYSTEM PRELIMINARY INSPECTION</b> .....	22
Component Parts Location .....	8	Inspection Procedure .....	22
Component Description .....	9	<b>POWER GENERATION VOLTAGE VARIABLE CONTROL SYSTEM OPERATION INSPECTION</b> .....	23
<b>DTC/CIRCUIT DIAGNOSIS</b> .....	10	Inspection Procedure .....	23
<b>B TERMINAL CIRCUIT</b> .....	10	<b>REMOVAL AND INSTALLATION</b> .....	25
Description .....	10	<b>ALTERNATOR</b> .....	25
Diagnosis Procedure .....	10	<b>2WD</b> .....	25
<b>L TERMINAL CIRCUIT (OPEN)</b> .....	11	2WD : Exploded View .....	25
Description .....	11	2WD : Removal and Installation .....	26
Diagnosis Procedure .....	11	2WD : Inspection .....	27
<b>L TERMINAL CIRCUIT (SHORT)</b> .....	13	<b>AWD</b> .....	27
Description .....	13	AWD : Exploded View .....	27
Diagnosis Procedure .....	13	AWD : Removal and Installation .....	28
<b>S TERMINAL CIRCUIT</b> .....	14	AWD : Inspection .....	29
Description .....	14		
Diagnosis Procedure .....	14		
<b>CHARGING SYSTEM</b> .....	15		
Wiring Diagram - CHARGING SYSTEM - .....	15		
<b>SYMPTOM DIAGNOSIS</b> .....	19		

CHG

---

**SERVICE DATA AND SPECIFICATIONS**  
**(SDS)** ..... 30

**SERVICE DATA AND SPECIFICATIONS**  
**(SDS)** ..... 30  
    Alternator ..... 30

# DIAGNOSIS AND REPAIR WORKFLOW

< BASIC INSPECTION >

## BASIC INSPECTION

### DIAGNOSIS AND REPAIR WORKFLOW

Work Flow

INFOID:000000006452491

#### OVEROALL SEQUENCE

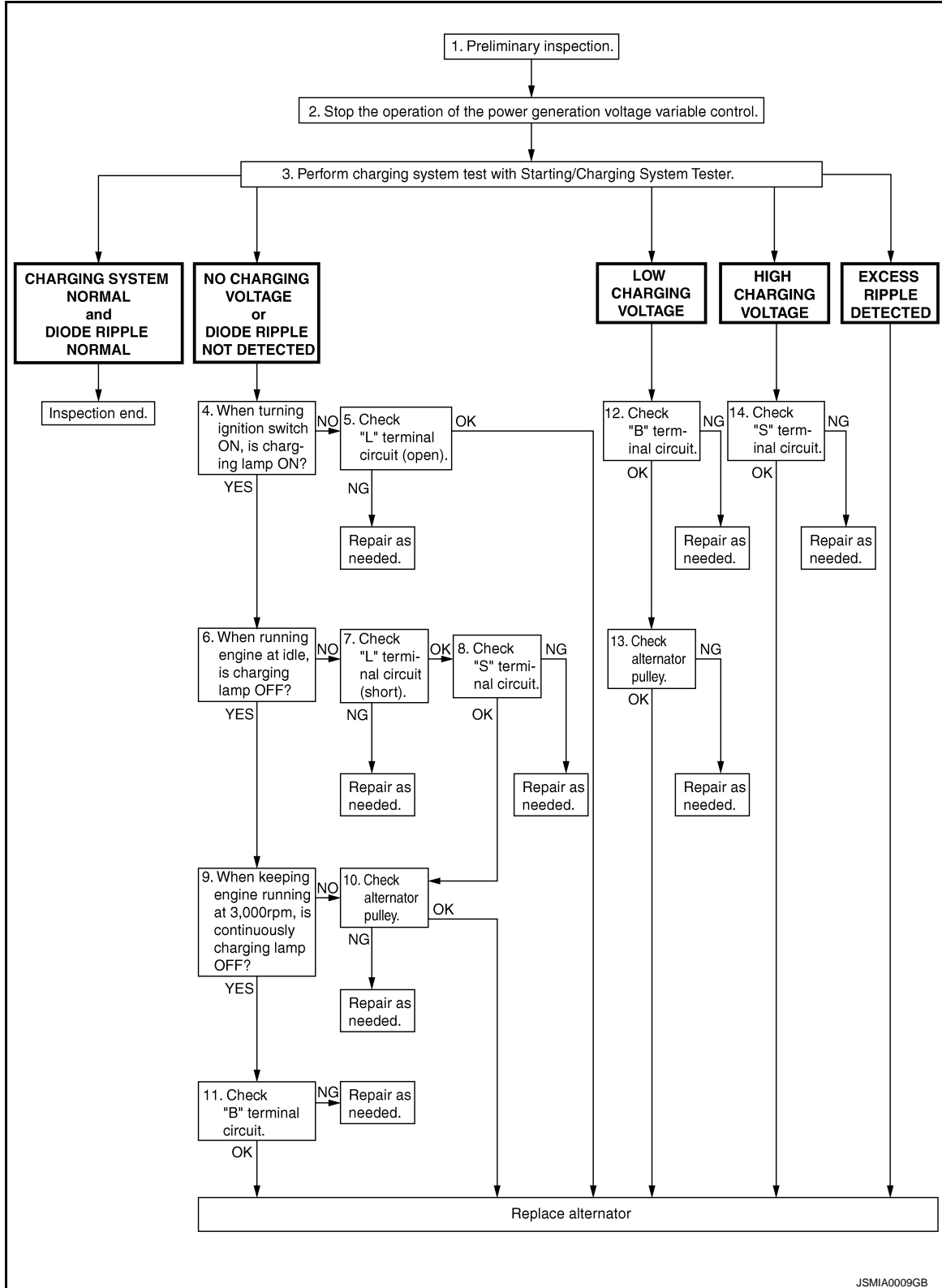

DETAILED FLOW

A  
B  
C  
D  
E  
F  
G  
H  
I  
J  
K  
L  
N  
O  
P

CHG

JSMIA0009GB

# DIAGNOSIS AND REPAIR WORKFLOW

## < BASIC INSPECTION >

---

### NOTE:

To ensure a complete and thorough diagnosis, the battery, starter and alternator test segments must be done as a set from start to finish.

### 1. PRELIMINARY INSPECTION

---

Perform the preliminary inspection. Refer to [CHG-22, "Inspection Procedure"](#).

>> GO TO 2.

### 2. STOP POWER GENERATION VOLTAGE VARIABLE CONTROL SYSTEM

---

Stop the operation of the power generation voltage variable control in either of the following procedures.

- After selecting "ENGINE" of "SELECT SYSTEM" using CONSULT-III, set the DUTY value of "ALTERNATOR DUTY" to 0 % by selecting "ALTERNATOR DUTY" of "Active Test". Continue "Active Test" until the end of inspection. (When the DUTY value is 0 or 100 %, the normal power generation is performed according to the characteristic of the IC voltage regulator of the alternator.)
- Turn the ignition switch OFF, and disconnect the battery current sensor connector. [However, DTC (P1550 - P1554) of the engine might remain. After finishing the inspection, connect the battery current sensor connector and erase the self-diagnostic results history of the engine using CONSULT-III.]

>> GO TO 3.

### 3. DIAGNOSIS WITH STARTING/CHARGING SYSTEM TESTER

---

Perform the charging system test using Starting/Charging System Tester (SST: J-44373). For details and operating instructions, refer to Technical Service Bulletin.

#### Test result

CHARGING SYSTEM NORMAL>>Charging system is normal and will also show "DIODE RIPPLE" test result.

NO CHARGING VOLTAGE>>GO TO 4.

LOW CHARGING VOLTAGE>>GO TO 12.

HIGH CHARGING VOLTAGE>>GO TO 14.

DIODE RIPPLE NORMAL>>Diode ripple is OK and will also show "CHARGING VOLTAGE" test result.

EXCESS RIPPLE DETECTED>>Replace the alternator. Perform "DIODE RIPPLE" test again using Starting/Charging System Tester (SST: J-44373) to confirm repair.

DIODE RIPPLE NOT DETECTED>>GO TO 4.

### 4. INSPECTION WITH CHARGE WARNING LAMP (IGNITION SWITCH IS ON)

---

Turn the ignition switch ON.

Does the charge warning lamp illuminate?

YES >> GO TO 6.

NO >> GO TO 5.

### 5. "L" TERMINAL CIRCUIT (OPEN) INSPECTION

---

Check "L" terminal circuit (open). Refer to [CHG-11, "Diagnosis Procedure"](#).

Is the "L" terminal circuit normal?

YES >> Replace alternator.

NO >> Repair as needed.

### 6. INSPECTION WITH CHARGE WARNING LAMP (IDLING)

---

Start the engine and run it at idle.

Does the charge warning lamp turn OFF?

YES >> GO TO 9.

NO >> GO TO 7.

### 7. "L" TERMINAL CIRCUIT (SHORT) INSPECTION

---

Check "L" terminal circuit (short). Refer to [CHG-13, "Diagnosis Procedure"](#).

Is the "L" terminal circuit normal?

YES >> GO TO 8.

NO >> Repair as needed.

# DIAGNOSIS AND REPAIR WORKFLOW

< BASIC INSPECTION >

---

## 8. "S" TERMINAL CIRCUIT INSPECTION

---

Check "S" terminal circuit. Refer to [CHG-14. "Diagnosis Procedure"](#).

Is the "S" terminal circuit normal?

YES >> GO TO 10.

NO >> Repair as needed.

---

## 9. INSPECTION WITH CHARGE WARNING LAMP (ENGINE AT 3,000 RPM)

---

Increase and maintain the engine speed at 3,000 rpm.

Does the charge warning lamp remain off?

YES >> GO TO 11.

NO >> GO TO 10.

---

## 10. INSPECTION OF ALTERNATOR PULLEY

---

Check alternator pulley. Refer to [CHG-27. "2WD : Inspection"](#) (2WD) or [CHG-29. "AWD : Inspection"](#) (AWD).

Is alternator pulley normal?

YES >> Replace alternator.

NO >> Repair as needed.

---

## 11. "B" TERMINAL CIRCUIT INSPECTION

---

Check "B" terminal circuit. Refer to [CHG-10. "Diagnosis Procedure"](#).

Is "B" terminal circuit normal?

YES >> Replace alternator.

NO >> Repair as needed.

---

## 12. "B" TERMINAL CIRCUIT INSPECTION

---

Check "B" terminal circuit. Refer to [CHG-10. "Diagnosis Procedure"](#).

Is "B" terminal circuit normal?

YES >> GO TO 13.

NO >> Repair as needed.

---

## 13. INSPECTION OF ALTERNATOR PULLEY

---

Check alternator pulley. Refer to [CHG-27. "2WD : Inspection"](#) (2WD) or [CHG-29. "AWD : Inspection"](#) (AWD).

Is alternator pulley normal?

YES >> Replace alternator.

NO >> Repair as needed.

---

## 14. "S" TERMINAL CIRCUIT INSPECTION

---

Check "S" terminal circuit. Refer to [CHG-14. "Diagnosis Procedure"](#).

Is the "S" terminal circuit normal?

YES >> Replace alternator.

NO >> Repair as needed.

A  
B  
C  
D  
E  
F  
G  
H  
I  
J  
K  
L  
N  
O  
P

CHG

# CHARGING SYSTEM

< SYSTEM DESCRIPTION >

## SYSTEM DESCRIPTION

### CHARGING SYSTEM

#### System Diagram

INFOID:000000006452492

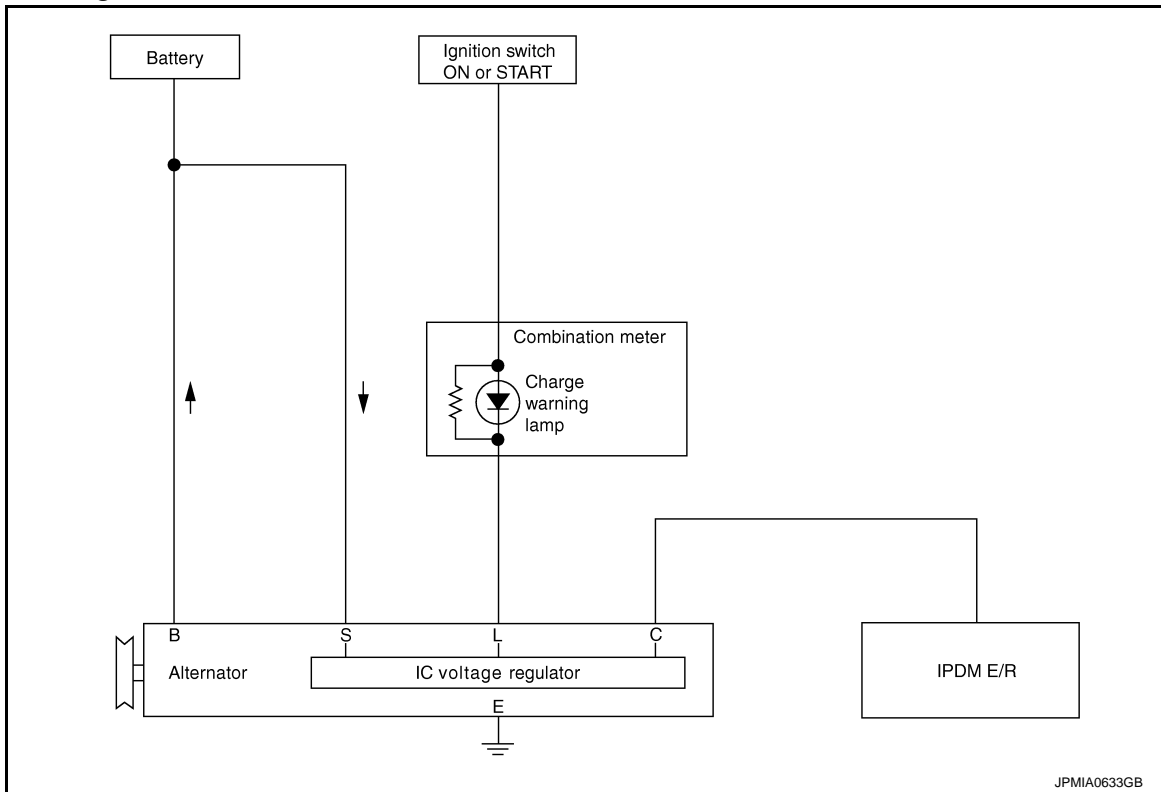

JPMIA0633GB

#### System Description

INFOID:000000006452493

The alternator provides DC voltage to operate the vehicle's electrical system and to keep the battery charged. The voltage output is controlled by the IC voltage regulator.

#### Component Parts Location

INFOID:000000006452494

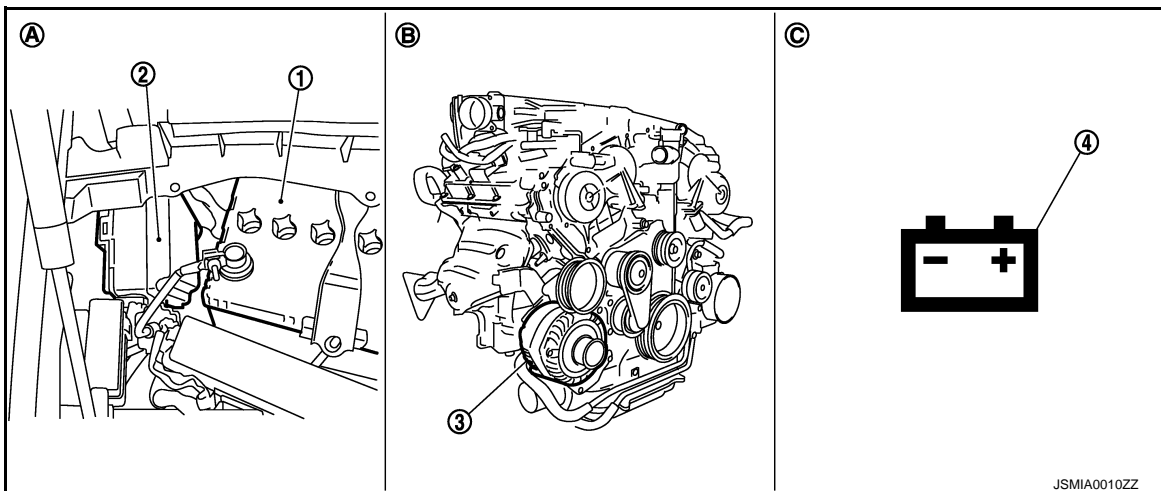

JSMIA0010ZZ

- |                                |             |                      |
|--------------------------------|-------------|----------------------|
| 1. Battery                     | 2. IPDM E/R | 3. Alternator        |
| 4. Charge warning lamp         | B. Engine   | C. Combination meter |
| A. Engine room dash panel (RH) |             |                      |

# CHARGING SYSTEM

< SYSTEM DESCRIPTION >

## Component Description

INFOID:000000006452495

Component part		Description
Alternator	"B" terminal	Refer to <a href="#">CHG-10, "Description"</a> .
	"S" terminal	Refer to <a href="#">CHG-14, "Description"</a> .
	"L" terminal	Refer to <a href="#">CHG-11, "Description"</a> .
	"C" terminal	Used for the power generation voltage variable control system. Refer to <a href="#">CHG-8, "System Description"</a> .
Combination meter (Charge warning lamp)		The IC voltage regulator warning function activates to illuminate the charge warning lamp, if any of the following symptoms occur while alternator is operating: <ul style="list-style-type: none"> <li>• Excessive voltage is produced.</li> <li>• No voltage is produced.</li> </ul>
IPDM E/R		Used for the power generation voltage variable control system. Refer to <a href="#">CHG-8, "System Description"</a> .

A  
B  
C  
D  
E  
F  
G  
H  
I  
J  
K  
L  
N  
O  
P

CHG

# POWER GENERATION VOLTAGE VARIABLE CONTROL SYSTEM

< SYSTEM DESCRIPTION >

## POWER GENERATION VOLTAGE VARIABLE CONTROL SYSTEM

### System Diagram

INFOID:000000006452496

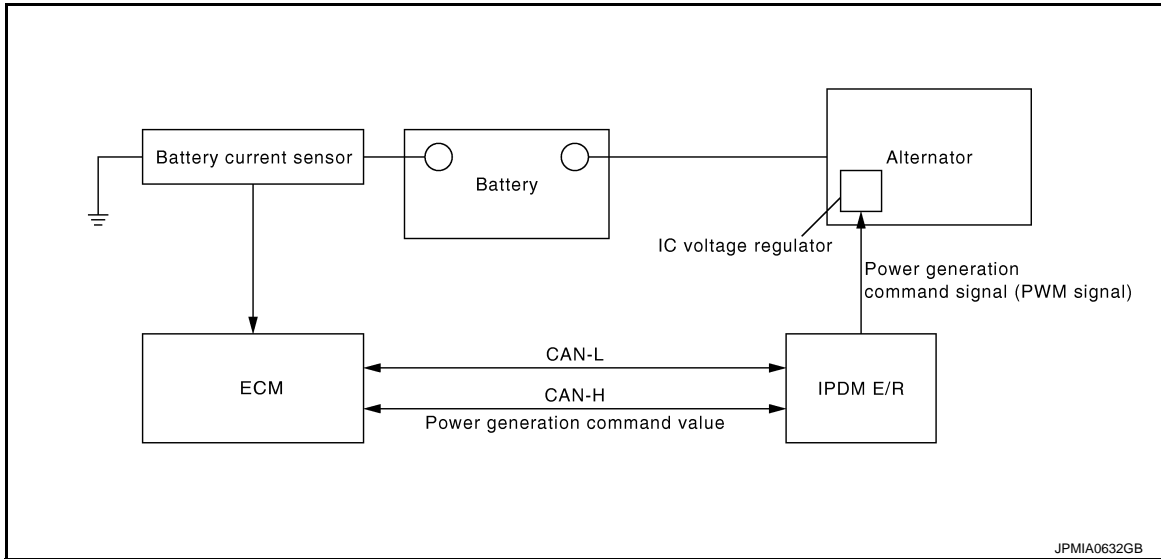

### System Description

INFOID:000000006452497

By performing the power generation voltage variable control, the engine load due to the power generation of the alternator is reduced and fuel consumption is decreased.

**NOTE:**

When any malfunction is detected in the power generation voltage variable control system, the power generation is performed according to the characteristic of the IC voltage regulator of the alternator.

### Component Parts Location

INFOID:000000006452498



- |                                |                     |                           |
|--------------------------------|---------------------|---------------------------|
| 1. Battery                     | 2. IPDM E/R         | 3. Battery current sensor |
| 4. ECM                         | 5. Alternator       |                           |
| A. Engine room dash panel (RH) | B. Behind glove box | C. Engine                 |



# POWER GENERATION VOLTAGE VARIABLE CONTROL SYSTEM

< SYSTEM DESCRIPTION >

## Component Description

INFOID:000000006452499

Component part	Description
Battery current sensor	Battery current sensor is installed to the battery cable at the negative terminal, and it detects the charging/discharging current of the battery and sends the voltage signal to ECM according to the current value.
ECM	Battery current sensor detects the charging/discharging current of the battery. ECM judges the battery condition based on this signal. ECM judges whether to perform the power generation voltage variable control according to the battery condition. When performing the power generation voltage variable control, ECM calculates the target power generation voltage according to the battery condition and sends the calculated value as the power generation command value to IPDM E/R.
IPDM E/R	IPDM E/R converts the received power generation command value into the power generation command signal (PWM signal) and sends it to the IC voltage regulator.
Alternator (IC voltage regulator)	IC voltage regulator controls the power generation voltage by the target power generation voltage based on the received power generation command signal. When there is no power generation command signal, the alternator performs the normal power generation according to the characteristic of the IC voltage regulator.

A  
B  
C  
D  
E  
F  
G  
H  
I  
J  
K  
L  
N  
O  
P

CHG

# B TERMINAL CIRCUIT

< DTC/CIRCUIT DIAGNOSIS >

## DTC/CIRCUIT DIAGNOSIS

### B TERMINAL CIRCUIT

#### Description

INFOID:000000006452500

"B" terminal circuit supplies power to charge the battery and to operate the vehicle's electrical system.

#### Diagnosis Procedure

INFOID:000000006452501

#### 1. CHECK "B" TERMINAL CONNECTION

1. Turn ignition switch OFF.
2. Check if "B" terminal is clean and tight.

Is the inspection result normal?

YES >> GO TO 2.

NO >> Repair "B" terminal connection. Confirm repair by performing complete Starting/Charging system test. Refer to Technical Service Bulletin.

#### 2. CHECK "B" TERMINAL CIRCUIT

Check voltage between alternator "B" terminal and ground.

Terminals			Voltage (Approx.)
(+)	(-)		
Alternator "B" terminal	Terminal		Battery voltage
E203	1	Ground	

Is the inspection result normal?

YES >> GO TO 3.

NO >> Check harness for open between alternator and fusible link.

#### 3. CHECK "B" TERMINAL CONNECTION (VOLTAGE DROP TEST)

1. Start engine, then engine running at idle and warm.
2. Check voltage between battery positive terminal and alternator "B" terminal.

Terminals			Voltage (Approx.)
(+)	(-)		
Battery positive terminal	Alternator "B" terminal	Terminal	Less than 0.2 V
	E203	1	

Is the inspection result normal?

YES >> "B" terminal circuit is normal. Refer to [CHG-3, "Work Flow"](#).

NO >> Check harness between battery and alternator for poor continuity.

# L TERMINAL CIRCUIT (OPEN)

< DTC/CIRCUIT DIAGNOSIS >

## L TERMINAL CIRCUIT (OPEN)

### Description

INFOID:000000006452502

The "L" terminal circuit controls the charge warning lamp. The charge warning lamp illuminates when the ignition switch is set to ON or START. When the alternator is providing sufficient voltage with the engine running, the charge warning lamp will go off. If the charge warning lamp illuminates with the engine running, a malfunction is indicated.

### Diagnosis Procedure

INFOID:000000006452503

#### 1. CHECK "L" TERMINAL CONNECTION

1. Turn ignition switch OFF.
2. Check if "L" terminal is clean and tight.

Is the inspection result normal?

YES >> GO TO 2.

NO >> Repair "L" terminal connection. Confirm repair by performing complete Starting/Charging system test. Refer to Technical Service Bulletin.

#### 2. CHECK "L" TERMINAL CIRCUIT (OPEN)

1. Disconnect alternator connector.
2. Apply ground to alternator harness connector terminal.
3. Check condition of the charge warning lamp with the ignition switch in the ON position.

Alternator harness connector	Terminal	Ground	Condition	
			Ignition switch position	Charge warning lamp
F36	2		ON	illuminate

Does it illuminate?

YES >> "L" terminal circuit is normal. Refer to [CHG-3. "Work Flow"](#).

NO >> GO TO 3.

#### 3. CHECK HARNESS CONTINUITY (OPEN CIRCUIT)

1. Disconnect the battery cable from the negative terminal.
2. Disconnect the combination meter connector.
3. Check continuity between alternator harness connector and combination meter harness connector.

Alternator harness connector		Combination meter harness connector		Continuity
Connector No.	Terminal No.	Connector No.	Terminal No.	
F36	2	M53	6	Existed

Is the inspection result normal?

YES >> GO TO 4.

NO >> Repair the harness or connector.

#### 4. CHECK HARNESS CONTINUITY (OPEN CIRCUIT)

Check continuity between combination meter harness connector and fuse block.

Combination meter harness connector		Fuse block		Continuity
Connector No.	Terminal No.	Connector No.	Terminal No.	
M53	21	M3	12C	Existed

Is the inspection result normal?

YES >> GO TO 5.

NO >> Repair the harness.

#### 5. CHECK POWER SUPPLY CIRCUIT

1. Connect the battery cable to the negative terminal.

A  
B  
C  
D  
E  
F  
G  
H  
I  
J  
K  
L

CHG

N  
O  
P

## L TERMINAL CIRCUIT (OPEN)

< DTC/CIRCUIT DIAGNOSIS >

2. Check voltage between combination meter harness connector and ground.

Terminals		(-)	Condition	Voltage (Approx.)
(+)	Terminal			
Combination meter harness connector				
M53	21	Ground	When the ignition switch is in ON position	Battery voltage

Is the inspection result normal?

YES >> Replace combination meter.

NO >> Inspect the power supply circuit. Refer to [PG-67, "Wiring Diagram - IGNITION POWER SUPPLY -](#)

["](#)

# L TERMINAL CIRCUIT (SHORT)

< DTC/CIRCUIT DIAGNOSIS >

## L TERMINAL CIRCUIT (SHORT)

### Description

INFOID:000000006452504

The "L" terminal circuit controls the charge warning lamp. The charge warning lamp illuminates when the ignition switch is set to ON or START. When the alternator is providing sufficient voltage with the engine running, the charge warning lamp will go off. If the charge warning lamp illuminates with the engine running, a malfunction is indicated.

### Diagnosis Procedure

INFOID:000000006452505

#### 1. CHECK "L" TERMINAL CIRCUIT (SHORT)

1. Turn ignition switch OFF.
2. Disconnect alternator connector.
3. Turn ignition switch ON.

Does charge warning lamp illuminate?

YES >> GO TO 2.

NO >> Refer to [CHG-3. "Work Flow"](#).

#### 2. CHECK HARNESS CONTINUITY (SHORT CIRCUIT)

1. Turn the ignition switch OFF.
2. Disconnect the battery cable from the negative terminal.
3. Disconnect combination meter connector.
4. Check continuity between combination meter harness connector and ground.

Combination meter harness connector		Ground	Continuity
Connector No.	Terminal No.		
M53	6		Not existed

Is the inspection result normal?

YES >> Replace combination meter.

NO >> Repair the harness.

CHG

# S TERMINAL CIRCUIT

< DTC/CIRCUIT DIAGNOSIS >

## S TERMINAL CIRCUIT

### Description

INFOID:000000006452506

The output voltage of the alternator is controlled by the IC voltage regulator at the "S" terminal detecting the input voltage.

The "S" terminal circuit detects the battery voltage to adjust the alternator output voltage with the IC voltage regulator.

### Diagnosis Procedure

INFOID:000000006452507

#### 1. CHECK "S" TERMINAL CONNECTION

1. Turn ignition switch OFF.
2. Check if "S" terminal is clean and tight.

Is the inspection result normal?

YES >> GO TO 2.

NO >> Repair "S" terminal connection. Confirm repair by performing complete Starting/Charging system test. Refer to Technical Service Bulletin.

#### 2. CHECK "S" TERMINAL CIRCUIT

Check voltage between alternator harness connector and ground.

Terminals		Voltage (Approx.)
(+)	(-)	
Alternator harness connector	Terminal	Battery voltage
F36	3	
	Ground	

Is the inspection result normal?

YES >> Refer to [CHG-3, "Work Flow"](#).

NO >> Check harness for open between alternator and fuse.

# CHARGING SYSTEM

< DTC/CIRCUIT DIAGNOSIS >

## CHARGING SYSTEM

### Wiring Diagram - CHARGING SYSTEM -

INFOID:000000006452508

A  
B  
C  
D  
E  
F  
G  
H  
I  
J  
K  
L  
N  
O  
P

### CHARGING SYSTEM

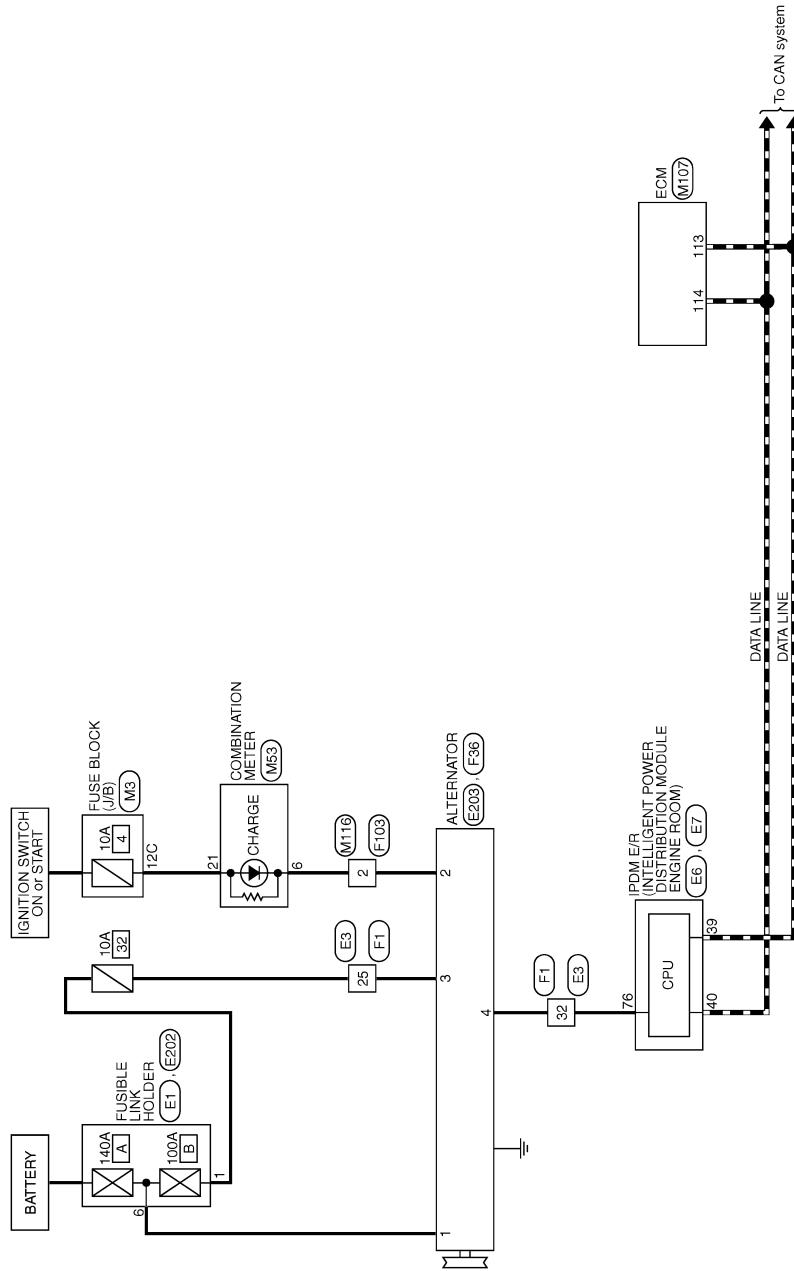

CHG

# CHARGING SYSTEM

< DTC/CIRCUIT DIAGNOSIS >

## CHARGING SYSTEM

Connector No.	E1
Connector Name	FUSIBLE LINK HOLDER
Connector Type	LOPER-MC



Terminal No.	Color of Wire	Signal Name [Specification]
1	R	-
2	W	-

Connector No.	E3
Connector Name	WIRE TO WIRE
Connector Type	SAA30MB-FSS-SHZ3

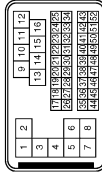

Terminal No.	Color of Wire	Signal Name [Specification]
1	L/Y	-
2	SHIELD	-
3	L/B	-
4	SHIELD	-
5	BR	-
7	G	-
8	W	-
9	W	-
10	Y	-
11	P	-
12	SB	-
13	BR	-
14	G	-
15	R	-
16	LG	-
17	P	-
18	Y	-
19	EG	-
20	B	-
21	SB	-

22	W	-
23	L	-
24	G	-
25	V	-
27	GR	-
28	V	-
29	P	-
30	R	-
31	BR	-
32	Y	-
33	G	-
34	BG	-
37	SHIELD	-
38	L	-
39	P	-
40	R	-
41	W	-
42	LG	-
43	G	-
45	BG	-
46	SHIELD	-
47	W	-
48	BR	-
49	G	-
50	B	-
51	SB	-
52	R	-

Connector No.	E6
Connector Name	BPM E/R INTELLIGENT POWER DISTRIBUTION MODULE (ENGINE ROOM)
Connector Type	TH40BFW-NH



Terminal No.	Color of Wire	Signal Name [Specification]
39	P	-
40	L	-
41	B/W	-
42	Y	-
43	SB	-
44	LG	-
45	G	-
46	W	-

Connector No.	E7
Connector Name	BPM E/R INTELLIGENT POWER DISTRIBUTION MODULE (ENGINE ROOM)
Connector Type	TH40BFW-CS12-M4



Terminal No.	Color of Wire	Signal Name [Specification]
48	BR	-
49	BG	-
51	Y	-
53	W	-
54	P	-
55	SB	-
56	LG	-
57	G	-
58	GR	-
69	BR	-
70	BG	-
73	P	-
74	G	-
75	SB	-
76	Y	-
77	R	-
80	W	-

Connector No.	E202
Connector Name	FUSIBLE LINK HOLDER
Connector Type	24340-79095



Terminal No.	Color of Wire	Signal Name [Specification]
6	B/GR	-

Connector No.	E203
Connector Name	AL-TERMINATOR
Connector Type	24340-69F45



Terminal No.	Color of Wire	Signal Name [Specification]
1	B/GR	B



# CHARGING SYSTEM

< DTC/CIRCUIT DIAGNOSIS >

## CHARGING SYSTEM

Connector No.	F1
Connector Name	WIRE TO WIRE
Connector Type	SA33PF-RSS-S1Z3

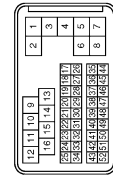

Terminal No.	Color of Wire	Signal Name [Specification]
1	L/Y	-
2	SHIELD	-
3	L/B	-
4	SHIELD	-
5	BR	-
7	G	-
8	W	-
9	W	-
10	G	-
11	R	-
12	P	-
13	L	-
14	LG	-
15	R	-
16	Y	- [2WD models]
16	O	- [AWD models]
17	W	-
18	LG	-
19	P	- [2WD models]
19	SB	- [AWD models]
20	O	-
21	BR	-
22	G	-
23	Y	-
24	LG	-
25	V	-
27	GR	-
28	BR	-
29	L	-
30	R	-
31	P	-
32	W	-
33	SB	-
34	O	- [2WD models]
34	BR	- [AWD models]
37	SHIELD	-
38	Y	-

40	G	-
41	B	-
42	GR	-
43	R	-
45	O	-
46	SHIELD	-
47	W/L	-
48	LG	-
49	O/L	-
50	L/Y	-
51	W	-
52	L/G	-

Connector No.	F36
Connector Name	ALTERNATOR
Connector Type	HS30FEB



Terminal No.	Color of Wire	Signal Name [Specification]
1	G	-
2	G	L
3	V	S
4	W	C

Connector No.	F103
Connector Name	WIRE TO WIRE
Connector Type	TK33PF1-NS10

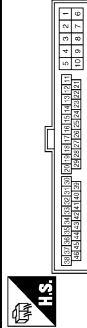

Terminal No.	Color of Wire	Signal Name [Specification]
2	G	-
3	W	-
4	R	-
5	B	-
9	Y	-

10	GR	-
19	O	-
20	Y	-
22	B	-
23	LG	-
30	R	-
31	R	-
33	B	-
34	B	-
35	L	-
36	P	-
37	Y	-
38	G	-
41	O	-
42	BR	-
43	P	-
44	L	-
45	G	-
46	V	-

Connector No.	M3
Connector Name	FUSE BLOCK (J/B)
Connector Type	MS12FW-CS



Terminal No.	Color of Wire	Signal Name [Specification]
8C	SB	-
9C	B	-
9C	W	-
9C	BG	-
10C	L	-
11C	LG	-
12C	G	-

Connector No.	MB3
Connector Name	COMBINATION METER
Connector Type	SB40FW

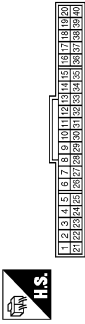

Terminal No.	Color of Wire	Signal Name [Specification]
1	V	BATTERY POWER SUPPLY
2	LG	COMMUNICATION SIGNAL (METER->AMP.)
3	GR	COMMUNICATION SIGNAL (AMP->METER)
5	B	GROUND
6	B	GROUND
9	W	ALTERNATOR SIGNAL
7	LG	AIR BAG SIGNAL
10	W	SECURITY SIGNAL
15	B	GROUND
16	BR	METER CONTROL SWITCH GROUND
18	GR	ILL. GND
19	B	ILL. GND
20	R	ILL.
21	G	IGNITION SIGNAL
22	B	GROUND
24	BR	COMMUNICATION SIGNAL (LCD->AMP.)
25	Y	COMMUNICATION SIGNAL (AMP->LCD)
26	R	VEHICLE SPEED SIGNAL (P-PULSE)
27	P	PARKING BRAKE SWITCH SIGNAL
28	SB	BRAKE FLUID LEVEL SWITCH
29	P	SEAT BELT BUCKLE SW SIGNAL (DRIVER SIDE)
30	G	SEAT BELT BUCKLE SWITCH SIGNAL (PASSENGER SIDE)
31	L	WASHER LEVEL SWITCH SIGNAL
33	R	ILLUMINATION CONTROL SIGNAL
36	LG	SELECT SWITCH SIGNAL
37	Y	ENTER SWITCH SIGNAL
38	P	TRIP A/B RESET SWITCH SIGNAL
39	P	ILLUMINATION CONTROL SWITCH SIGNAL (-)
40	BG	ILLUMINATION CONTROL SWITCH SIGNAL (+)

A B C D E F G H I J K L N O P

## CHG

# CHARGING SYSTEM

< DTC/CIRCUIT DIAGNOSIS >

## CHARGING SYSTEM

Connector No.	M107
Connector Name	ECM
Connector Type	RH24FG-R26-R-LH-Z

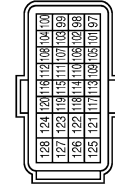

Terminal No.	Color of Wire	Signal Name [Specification]
97	R	APP SEN 1
98	P	APP SEN 2
99	L	SENSOR POWER SUPPLY
100	W	SENSOR GROUND
101	SB	ASCD/ICC STEERING SW
102	LG	EVAP CONTROL SYSTEM PRESS SEN
103	GR	SENSOR POWER SUPPLY
104	V	SENSOR GROUND
105	L	REFRIGERANT PRESS SEN
106	W	FUEL TANK TEMP SEN
107	GR	SENSOR POWER SUPPLY
108	Y	SENSOR GROUND
109	G	PNP SIGNAL
110	R	ENGINE SPEED OUTPUT SIGNAL
112	V	SENSOR GROUND
113	P	CAN COMMUNICATION LINE
114	L	CAN COMMUNICATION LINE
117	V	DATA LINK CONNECTOR
121	LG	EVAP CANISTER VENT CONTROL VALVE
122	P	STOP LAMP SW
123	B	ECM GROUND
124	B	ECM GROUND
125	R	POWER SUPPLY FOR ECM
126	BR	ASCD/ICC BRAKE SW
127	B	ECM GROUND
128	B	ECM GROUND

Connector No.	M116
Connector Name	WIRE TO WIRE
Connector Type	TK38MP-NS10



Terminal No.	Color of Wire	Signal Name [Specification]
2	W	
3	BG	
4	P	
5	B	
9	R	
10	R	
19	BG	
20	Y	
28	B	
29	LG	
30	LG	
31	W	
33	B	
34	B	
35	L	
36	P	
37	R	
38	SB	
41	BG	
42	G	
43	P	
44	L	
45	Y	
46	SB	

JCMWN0151GB

# CHARGING SYSTEM

< SYMPTOM DIAGNOSIS >

## SYMPTOM DIAGNOSIS

### CHARGING SYSTEM

#### Symptom Table

INFOID:000000006452509

Symptom	Reference
Discharged battery	Refer to <a href="#">CHG-3, "Work Flow"</a> .
The charge warning lamp does not illuminate when the ignition switch is set to ON.	
The charge warning lamp does not turn OFF after the engine starts.	
The charging warning lamp turns ON when increasing the engine speed.	

A

B

C

D

E

F

G

H

I

J

K

L

CHG

N

O

P

# PRECAUTIONS

< PRECAUTION >

## PRECAUTION

### PRECAUTIONS

#### Precaution for Supplemental Restraint System (SRS) "AIR BAG" and "SEAT BELT PRE-TENSIONER"

INFOID:000000006452510

The Supplemental Restraint System such as "AIR BAG" and "SEAT BELT PRE-TENSIONER", used along with a front seat belt, helps to reduce the risk or severity of injury to the driver and front passenger for certain types of collision. This system includes seat belt switch inputs and dual stage front air bag modules. The SRS system uses the seat belt switches to determine the front air bag deployment, and may only deploy one front air bag, depending on the severity of a collision and whether the front occupants are belted or unbelted. Information necessary to service the system safely is included in the "SRS AIR BAG" and "SEAT BELT" of this Service Manual.

#### **WARNING:**

Always observe the following items for preventing accidental activation.

- To avoid rendering the SRS inoperative, which could increase the risk of personal injury or death in the event of a collision that would result in air bag inflation, all maintenance must be performed by an authorized NISSAN/INFINITI dealer.
- Improper maintenance, including incorrect removal and installation of the SRS, can lead to personal injury caused by unintentional activation of the system. For removal of Spiral Cable and Air Bag Module, see "SRS AIR BAG".
- Never use electrical test equipment on any circuit related to the SRS unless instructed to in this Service Manual. SRS wiring harnesses can be identified by yellow and/or orange harnesses or harness connectors.

#### PRECAUTIONS WHEN USING POWER TOOLS (AIR OR ELECTRIC) AND HAMMERS

#### **WARNING:**

Always observe the following items for preventing accidental activation.

- When working near the Air Bag Diagnosis Sensor Unit or other Air Bag System sensors with the ignition ON or engine running, never use air or electric power tools or strike near the sensor(s) with a hammer. Heavy vibration could activate the sensor(s) and deploy the air bag(s), possibly causing serious injury.
- When using air or electric power tools or hammers, always switch the ignition OFF, disconnect the battery, and wait at least 3 minutes before performing any service.

#### Precaution for Power Generation Voltage Variable Control System

INFOID:000000006452511

#### **CAUTION:**

For this model, the battery current sensor that is installed to the battery cable at the negative terminal measures the charging/discharging current of the battery, and performs various controls. If the electrical component or the ground wire is connected directly to the battery terminal, the current other than that being measured with the battery current sensor is charging to or discharging from the battery. This condition causes the malfunction of the control, and then the battery discharge may occur. Do not connect the electrical component or the ground wire directly to the battery terminal.

# PREPARATION

< PREPARATION >

## PREPARATION

### PREPARATION

#### Special Service Tools

INFOID:000000006452512

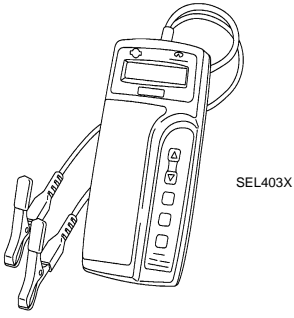
Tool number (Kent-Moore No.) Tool name	Description
<p>— (J-44373 Model MCR620) Starting/Charging System Tester</p>  <p style="text-align: right;">SEL403X</p>	<p>Tests starting and charging systems. For operating instructions, refer to Technical Service Bulletin.</p>

#### Commercial Service Tools

INFOID:000000006452513

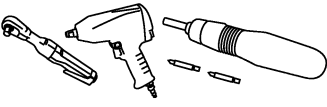
Tool name	Description
<p>Power tool</p>  <p style="text-align: right;">PIIB1407E</p>	<p>Loosening bolts, nuts and screws</p>

A

B

C

D

E

F

G

H

I

J

K

L

**CHG**

N

O

P

# CHARGING SYSTEM PRELIMINARY INSPECTION

< PERIODIC MAINTENANCE >

## PERIODIC MAINTENANCE

### CHARGING SYSTEM PRELIMINARY INSPECTION

#### Inspection Procedure

INFOID:000000006452514

#### 1. CHECK BATTERY TERMINALS CONNECTION

Check if battery terminals are clean and tight.

Is the inspection result normal?

YES >> GO TO 2.

NO >> Repair battery terminals connection.

#### 2. CHECK FUSE

Check for blown fuse and fusible link.

Unit	Power source (Power supply terminals)	Fuse No.
Alternator	Battery ("S" terminal)	32
Combination meter	Ignition switch ON ("L" terminal)	4

Is the inspection result normal?

YES >> GO TO 3.

NO >> Be sure to eliminate the cause of malfunction before installing new fuse.

#### 3. CHECK "E" TERMINAL CONNECTION (ALTERNATOR GROUND)

Check if "E" terminal (alternator ground) is clean and tight.

Is the inspection result normal?

YES >> GO TO 4.

NO >> Repair "E" terminal (alternator ground) connection.

#### 4. CHECK DRIVE BELT TENSION

Check drive belt tension. Refer to [EM-13. "Checking"](#).

Is the inspection result normal?

YES >> INSPECTION END

NO >> Repair as needed.

# POWER GENERATION VOLTAGE VARIABLE CONTROL SYSTEM OPERATION INSPECTION

< PERIODIC MAINTENANCE >

## POWER GENERATION VOLTAGE VARIABLE CONTROL SYSTEM OPERATION INSPECTION

### Inspection Procedure

INFOID:000000006452515

#### CAUTION:

When performing this inspection, always use a charged battery that has completed the battery inspection. (When the charging rate of the battery is low, the response speed of the voltage change will become slow. This can cause an incorrect inspection.)

### 1. CHECK ECM (CONSULT-III)

Perform ECM self-diagnosis with CONSULT-III. Refer to [EC-145. "CONSULT-III Function"](#).

#### Self-diagnostic results content

No malfunction detected>> GO TO 2.

Malfunction detected>> Check applicable parts, and repair or replace corresponding parts.

### 2. CHECK OPERATION OF POWER GENERATION VOLTAGE VARIABLE CONTROL SYSTEM

1. Connect CONSULT-III and start the engine.
2. The selector lever is in "P" or "N" position and all of the electric loads and A/C, etc. are turned OFF.
3. Select "ALTERNATOR DUTY" at "Active Test" of "ENGINE", and then check the value of "BATTERY VOLT" monitor when DUTY value of "ALTERNATOR DUTY" is set to 40.0%.

#### "BATTERY VOLT"

**2 seconds after setting the DUTY value of "ALTERNATOR DUTY" to 40.0%** : 12 - 13.6 V

4. Check the value of "BATTERY VOLT" monitor when DUTY value of "ALTERNATOR DUTY" is set to 80.0%.

#### "BATTERY VOLT"

**20 seconds after setting the DUTY value of "ALTERNATOR DUTY" to 80.0%** : +0.5 V or more against the value of "BATTERY VOLT" monitor when DUTY value is 40.0%

Is the measurement value within the specification?

YES >> INSPECTION END

NO >> GO TO 3.

### 3. CHECK IPDM E/R (CONSULT-III)

Perform IPDM E/R self-diagnosis with CONSULT-III. Refer to [PCS-12. "CONSULT-III Function \(IPDM E/R\)"](#).

#### Self-diagnostic results content

No malfunction detected>> GO TO 4.

Malfunction detected>> Check applicable parts, and repair or replace corresponding parts.

### 4. CHECK HARNESS BETWEEN ALTERNATOR AND IPDM E/R

1. Turn ignition switch OFF.
2. Disconnect alternator connector and IPDM E/R connector.
3. Check continuity between alternator harness connector and IPDM E/R harness connector.

Alternator harness connector		IPDM E/R harness connector		Continuity
Connector	Terminal	Connector	Terminal	
F36	4	E7	76	Existed

4. Check continuity between alternator harness connector and ground.

# POWER GENERATION VOLTAGE VARIABLE CONTROL SYSTEM OPERATION INSPECTION

< PERIODIC MAINTENANCE >

Alternator harness connector		Ground	Continuity
Connector	Terminal		
F36	4		Not existed

Is the inspection result normal?

YES >> Replace IPDM E/R.

NO >> Repair harness or connector between IPDM E/R and alternator.



# ALTERNATOR

< REMOVAL AND INSTALLATION >

## REMOVAL AND INSTALLATION

### ALTERNATOR

2WD

2WD : Exploded View

INFOID:000000006452516

### REMOVAL

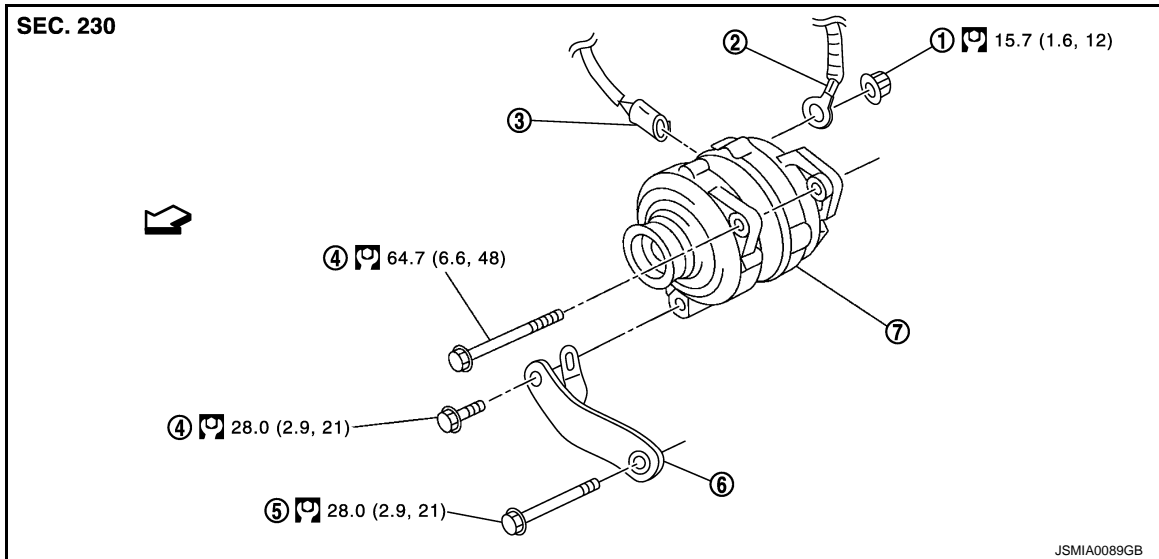

- |                             |                                  |                         |
|-----------------------------|----------------------------------|-------------------------|
| 1. "B" terminal nut         | 2. "B" terminal harness          | 3. Alternator connector |
| 4. Alternator mounting bolt | 5. Alternator stay mounting bolt | 6. Alternator stay      |
| 7. Alternator               |                                  |                         |

⇨ : Engine front

Refer to [GI-4, "Components"](#) for symbols in the figure.

### DISASSEMBLY

Type: A003TJ1991

A  
B  
C  
D  
E  
F  
G  
H  
I  
J  
K  
L  
N  
O  
P

CHG

# ALTERNATOR

## < REMOVAL AND INSTALLATION >

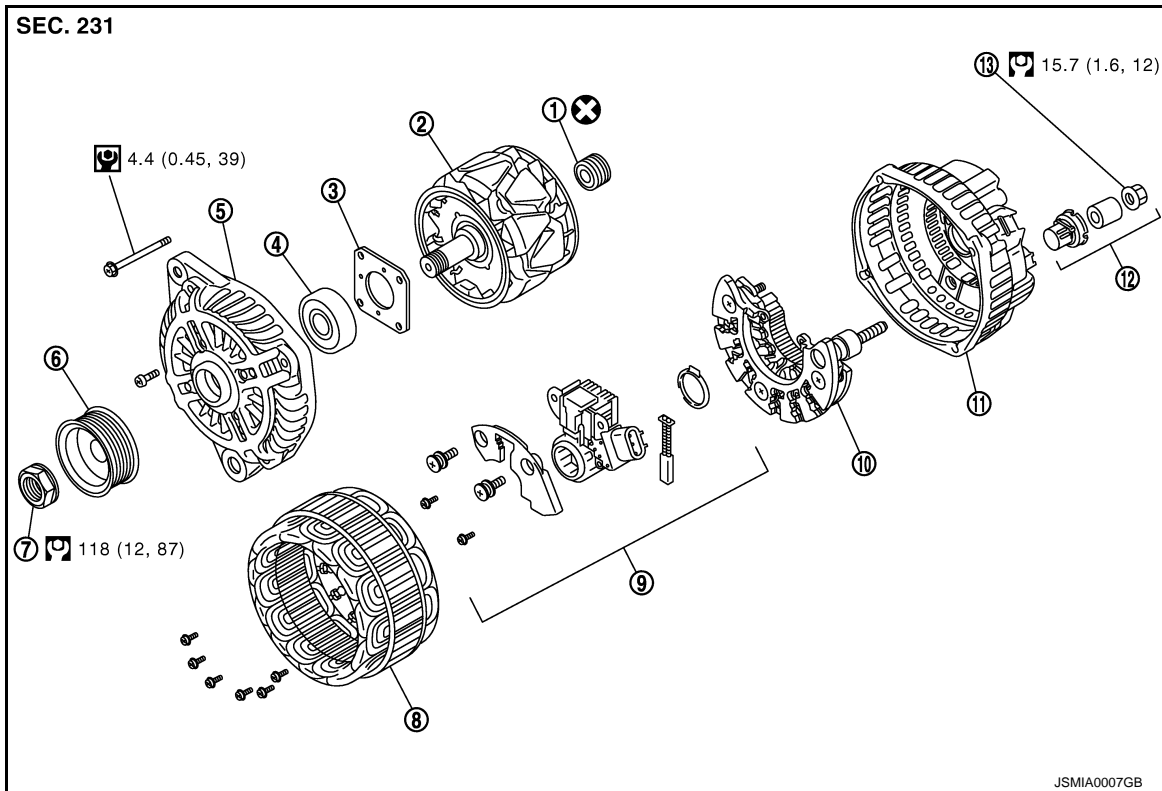

- |                      |                           |                                  |
|----------------------|---------------------------|----------------------------------|
| 1. Rear bearing      | 2. Rotor assembly         | 3. Retainer                      |
| 4. Front bearing     | 5. Front bracket assembly | 6. Pulley                        |
| 7. Pulley nut        | 8. Stator assembly        | 9. IC voltage regulator assembly |
| 10. Diode assembly   | 11. Rear bracket assembly | 12. Terminal set                 |
| 13. "B" terminal nut |                           |                                  |

Refer to [GI-4, "Components"](#) for symbols in the figure.

## 2WD : Removal and Installation

INFOID:000000006452517

### REMOVAL

1. Disconnect the battery cable from the negative terminal.
2. Remove engine front undercover, using power tools.
3. Remove radiator cooling fan assembly. Refer to [CO-17, "Exploded View"](#).
4. Remove drive belt. Refer to [EM-13, "Removal and Installation"](#).
5. Disconnect alternator connector (1).
6. Remove "B" terminal nut (2).
7. Remove the harness bracket bolts (A).

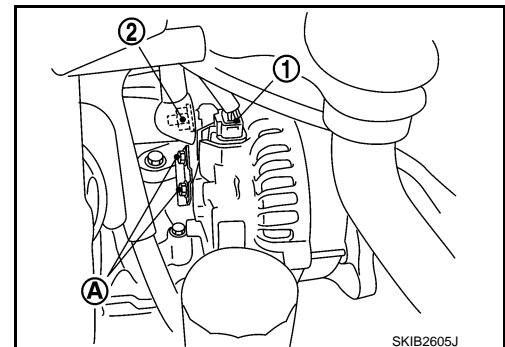

# ALTERNATOR

## < REMOVAL AND INSTALLATION >

8. Remove oil pressure switch harness clip (C) from alternator stay (1).
9. Disconnect oil pressure switch connector (D) and oil temperature sensor connector (E).
10. Remove alternator mounting bolt (B) and alternator stay mounting bolt (F) using power tools, then remove alternator stay.
11. Remove alternator mounting bolt (A), using power tools.

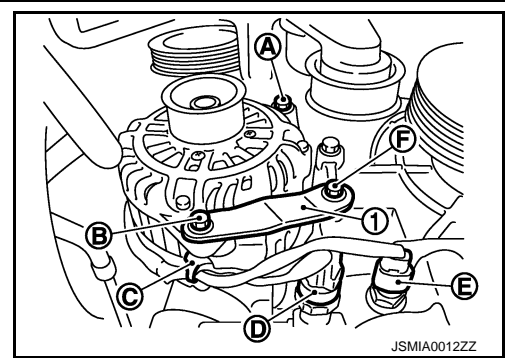

12. Remove alternator assembly downward from the vehicle.

## INSTALLATION

Install in the reverse order of removal.

### CAUTION:

**Be sure to tighten "B" terminal nut carefully.**

- Install alternator, and check tension of belt. Refer to [EM-13, "Checking"](#).
- For this model, the power generation voltage variable control system that controls the power generation voltage of the alternator has been adopted. Therefore, the power generation voltage variable control system operation inspection should be performed after replacing the alternator, and then make sure that the system operates normally. Refer to [CHG-23, "Inspection Procedure"](#).

## 2WD : Inspection

INFOID:000000006452518

## ALTERNATOR PULLEY INSPECTION

Perform the following.

- Make sure that alternator pulley does not rattle.
- Make sure that alternator pulley nut is tight. Refer to [CHG-25, "2WD : Exploded View"](#).

## AWD

## AWD : Exploded View

INFOID:000000006452519

## REMOVAL

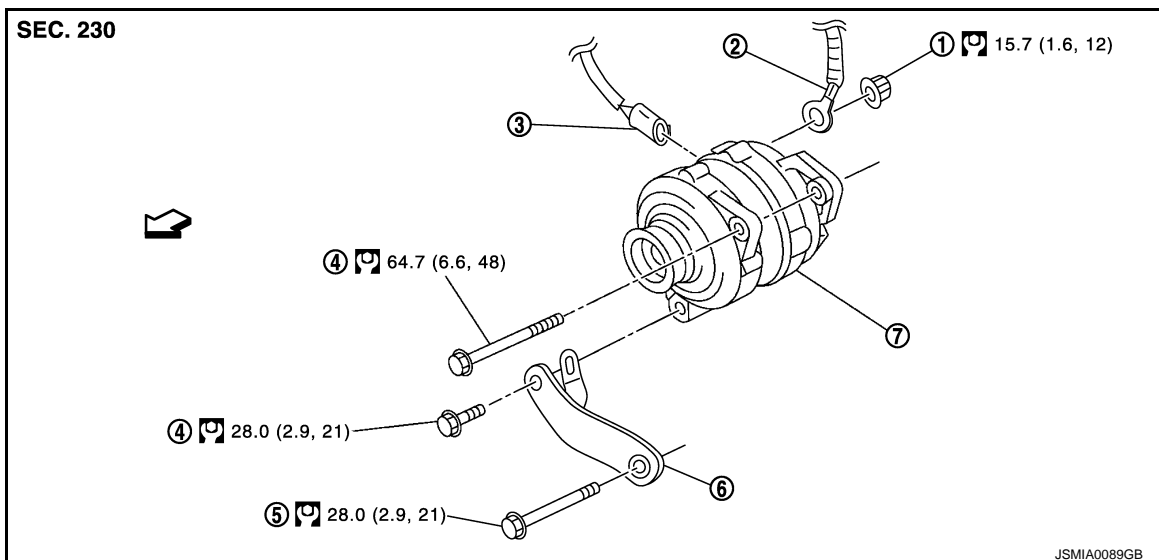

- |                             |                                  |                         |
|-----------------------------|----------------------------------|-------------------------|
| 1. "B" terminal nut         | 2. "B" terminal harness          | 3. Alternator connector |
| 4. Alternator mounting bolt | 5. Alternator stay mounting bolt | 6. Alternator stay      |
| 7. Alternator               |                                  |                         |

# ALTERNATOR

## < REMOVAL AND INSTALLATION >

↶ : Engine front

Refer to [GI-4. "Components"](#) for symbols in the figure.

### DISASSEMBLY

Type: A3TJ1991

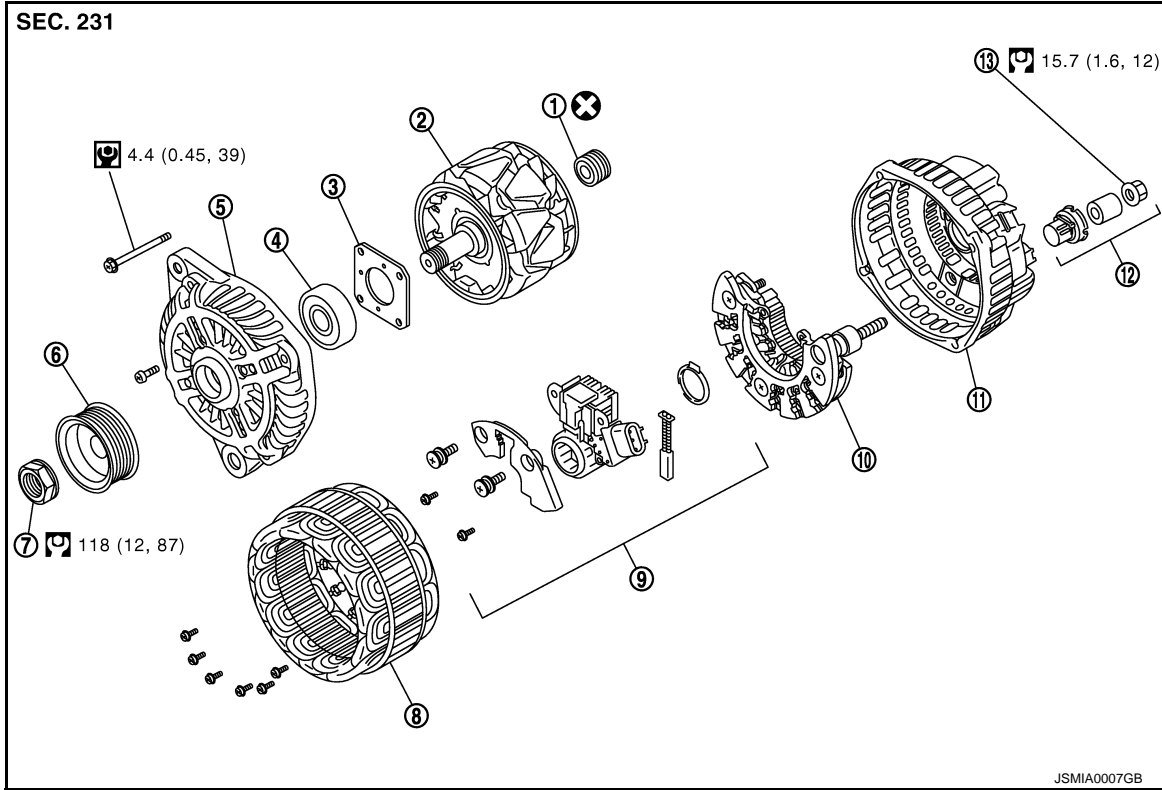

- |                      |                           |                                  |
|----------------------|---------------------------|----------------------------------|
| 1. Rear bearing      | 2. Rotor assembly         | 3. Retainer                      |
| 4. Front bearing     | 5. Front bracket assembly | 6. Pulley                        |
| 7. Pulley nut        | 8. Stator assembly        | 9. IC voltage regulator assembly |
| 10. Diode assembly   | 11. Rear bracket assembly | 12. Terminal set                 |
| 13. "B" terminal nut |                           |                                  |

Refer to [GI-4. "Components"](#) for symbols in the figure.

### AWD : Removal and Installation

INFOID:000000006452520

#### REMOVAL

1. Disconnect the battery cable from the negative terminal.
2. Remove air cleaner case (RH). Refer to [EM-27. "Exploded View"](#).
3. Remove the clip (B) from the harness bracket (1) and "B" terminal harness from the clip (C).
4. Disconnect pressure sensor connector (A).

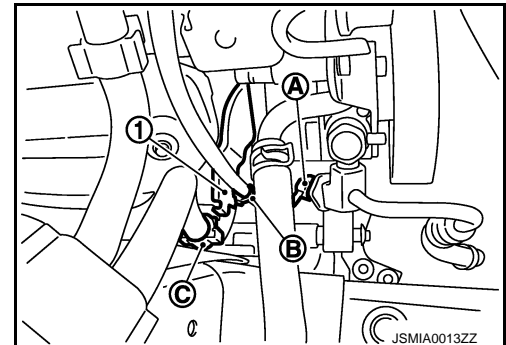

5. Remove engine undercover, using power tools.

# ALTERNATOR

## < REMOVAL AND INSTALLATION >

6. Remove radiator cooling fan assembly. Refer to [CO-17, "Exploded View"](#).
7. Remove drive belt. Refer to [EM-13, "Removal and Installation"](#).
8. Remove alternator mounting bolt (B) and alternator stay mounting bolt (C) using power tools, then remove alternator stay (1).
9. Remove alternator mounting bolt (A), using power tools.

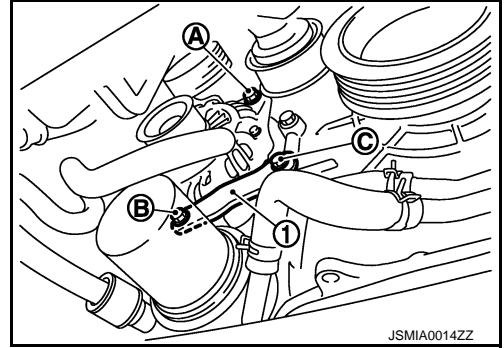

10. Pull and turn alternator, and then remove the harness bracket bolts (A).
11. Disconnect alternator connector (1).
12. Remove "B" terminal nut (2).

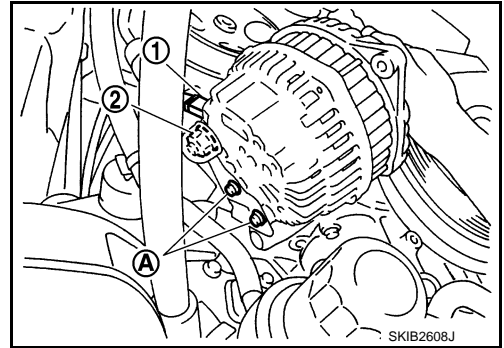

13. Remove alternator assembly downward from the vehicle.

## INSTALLATION

Install in the reverse order of removal.

### **CAUTION:**

**Be sure to tighten "B" terminal nut carefully.**

- Install alternator, and check tension of belt. Refer to [EM-13, "Checking"](#).
- For this model, the power generation voltage variable control system that controls the power generation voltage of the alternator has been adopted. Therefore, the power generation voltage variable control system operation inspection should be performed after replacing the alternator, and then make sure that the system operates normally. Refer to [CHG-23, "Inspection Procedure"](#).

## AWD : Inspection

INFOID:000000006452521

## ALTERNATOR PULLEY INSPECTION

Perform the following.

- Make sure that alternator pulley does not rattle.
- Make sure that alternator pulley nut is tight. Refer to [CHG-27, "AWD : Exploded View"](#).

A  
B  
C  
D  
E  
F  
G  
H  
I  
J  
K  
L  
N  
O  
P

CHG

## SERVICE DATA AND SPECIFICATIONS (SDS)

< SERVICE DATA AND SPECIFICATIONS (SDS)

# SERVICE DATA AND SPECIFICATIONS (SDS)

## SERVICE DATA AND SPECIFICATIONS (SDS)

### Alternator

INFOID:000000006452522

Type		A003TJ1991
		MITSUBISHI make
Nominal rating	[V - A]	12 -130
Ground polarity		Negative
Minimum revolution under no-load (When 13.5 V is applied)	[rpm]	Less than 1,300
Hot output current (When 13.5 V is applied)	[A/rpm]	More than 31/1,300 More than 122/2,500 More than 144/5,000
Regulated output voltage	[V]	14.1 - 14.7*
Minimum length of brush	[mm (in)]	More than 5.00 (0.197)
Brush spring pressure	[N (g, oz)]	4.1 - 5.3 (418 - 541, 14.7 - 19.1)
Slip ring minimum outer diameter	[mm (in)]	More than 22.1 (0.870)
Rotor (Field coil) resistance	[Ω]	1.7 - 2.0

\*: Adjustment range of power generation voltage variable control is 11.4 - 15.6 V.